

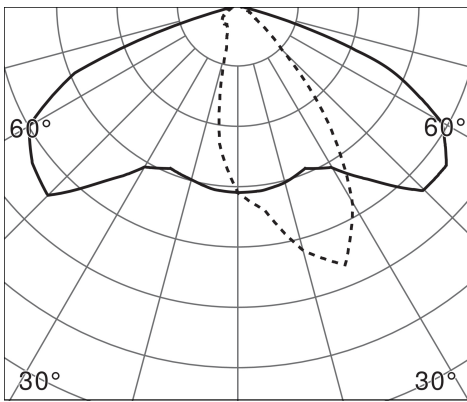

Description

- Projector 48S
- High pressure die cast aluminium one piece housing (AlSi12, with low copper rate)
- With translucent pc-cover, thickness 4mm, UV coated on both sides, frame material V2A steel 1mm, black powder coated, screwed with cap nuts
- White (RAL 9010)& Corrosionproof coating
- Special pretreatment for increased and long-lasting corrosion protection in chlorinated and saline environments
- Large choice of available accessories



Light specifications and controlling

- Net luminous flux: 2120 lm
- LED module luminous flux: 3560 lm
- Colour temperature: 5700 K
- CRI > 80
- SDCM <3
- Batwing asymmetric light distribution
- Beam angle : 120° - I_{max} at 23°
- ULR: 0 %
- With 1 integrated power unit, easily removable
- DALI dimmable LED Driver

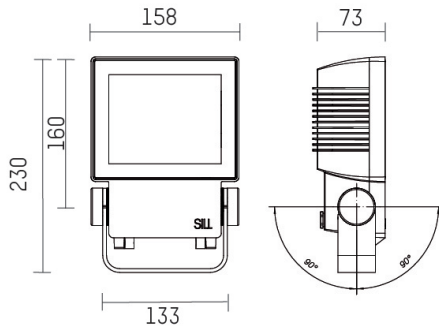

Installation and maintenance

- Dimensions : 230x 158 x 73 mm
- Pivot range ± 90°
- 1 cable gland M16 (capacity: Ø 6 to 8 mm)
- Connection to a 5 x 2,5 mm² fixed terminal block
- LED and drivers can be easily replaced by qualified personnel
- Wind-attack-area: 0,031 m²



Characteristics

- Warranty : 5 years
- 100 000 h L80/B10 at max. operating temperature
- Operating temperature: -25°C to +50°C
- Protection: IP65
- Resistance to IK shocks: IK08
- Class I
- Supply voltage: 220-240V 0/50/60Hz
- Power consumption: 28 W
- Mains surge immunity : <2 kV in common mode
- Power factor > 0,9
- Inrush current - I_{peak}: 5 A
- Peak duration - T_{width}: 50 µs
- Number of luminaires on automat type B16: 50 pcs
- Weight: 2,8 kg
- Manufactured according to DIN VDE 0711 / EN 60598, CE
- Designed and made in Germany - www.hoffmeister.com