

Description

- Projector 48L
- High pressure die cast aluminium one piece housing (AlSi12, with low copper rate)
- Very high mechanical, chemical and corrosion resistances
- With translucent pc-cover, thickness 4mm, UV coated on both sides, frame material V2A steel 1mm, black powder coated, screwed with cap nuts
- White (RAL 9010)& Corrosionproof coating
- Special pretreatment for increased and long-lasting corrosion protection in chlorinated and saline environments
- Large choice of available accessories

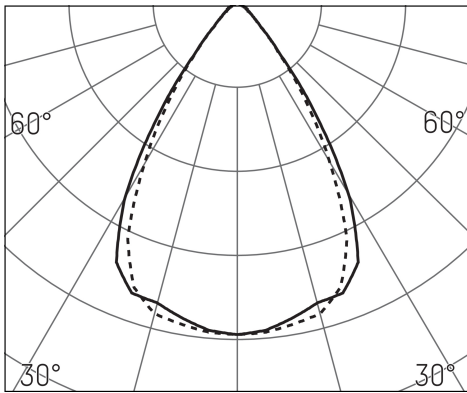

Light specifications and controlling

- Net luminous flux: 15370 lm
- LED module luminous flux: 17460 lm
- Colour temperature: 5700 K
- CRI > 80
- SDCM <3
- UGR ≤ 22
- Symmetrical light distribution, wide beam
- Beam angle : 65°
- ULR: 0 %
- With 1 industry rated integrated power unit, easily removable
- DALI dimmable LED Driver
- Automatic light regulation in case of overheating

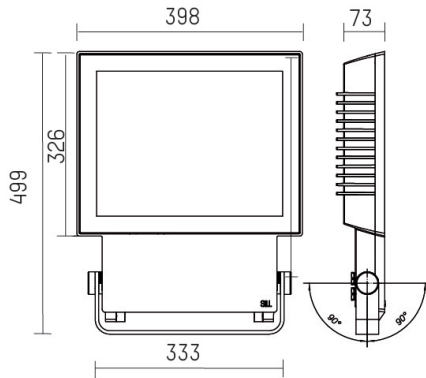

Installation and maintenance

- Dimensions : 499 × 398 × 73 mm
- Pivot range ± 90°
- 2 cable glands M20 (capacity: Ø 8 to 12 mm)
- Connection to a 2x 5 x 2,5 mm² fixed terminal block
- Wind-attack-area: 0,17 m²



Characteristics

- Warranty : 5 years
- 100 000 h L80/B10 at max. operating temperature
- Operating temperature -40°C to +50°C
- Protection: IP65
- Resistance to IK shocks: IK09
- Class I
- Supply voltage: 220-240V 0/50/60Hz
- Power consumption: 120 W
- Mains surge immunity : <8 kV in common mode
- Power factor > 0,95
- THD: 6 %
- Inrush current - Ipeak: 47 A
- Peak duration - Twidth: 250 µs
- Number of luminaires on automat type B16: 7 pcs
- Weight: 12 kg
- Manufactured according to DIN VDE 0711 / EN 60598, CE
- Designed and made in Germany - www.hoffmeister.com